



REPUBLIC OF NAURU

Government Gazette

Published by Authority

No. 13

23rd February, 1983.

Nauru.

G.N. No.128/1983.

CONSTITUTION OF NAURU

ASSIGNMENT OF RESPONSIBILITY FOR THE BUSINESS

OF GOVERNMENT

IN EXERCISE of the powers in that behalf vested in His Excellency The President, under article 23 of the Constitution of Nauru, I, BURARO DETUDAMO, being the Minister exercising the functions of His Excellency The President in Nauru under and by virtue of appointment as such by Cabinet under Article 21 of the Constitution of Nauru, hereby assign to the Ministers of the Cabinet of Nauru, as set out below the responsibilities of the business of the Government of Nauru as set out opposite their names:-

MINISTERS OF CABINET

BUSINESS OF GOVERNMENT

Minister for Justice

The Portfolio of the Minister for Island Development and Industry in relation to the business of Government to be undertaken in Nauru by the said Minister.

Minister for Health and Education

The Portfolio of the Minister for Finance in relation to the business of Government to be undertaken in Nauru by the said Minister.

The assignments of business of Government of Nauru as set out above is in addition to and not in substitution for the business of the Government of Nauru already assigned to the said Ministers. The above assignments of responsibility for the business of Government shall be effective during the absence from the Republic of the Honourable Kenas Aroi, M.P. Minister for Finance.

Given under my hand this 21st day of February, One Thousand Nine Hundred and Eighty-three.

BURARO DETUDAMO
ACTING CHAIRMAN OF THE CABINET

G.N. No.129/1983.

Determination of the Beneficiaries of the Estate of the late Eideberenimadang Obeta of Ijuw District.

E S T A T E

1. The Nauru Lands Committee has ascertained that the late Eideberenimadang had been determined by the decisions of the Nauru Lands Committee (or its predecessor the Lands Committee to be the owner of the following lands :-

District	Portion No.	Type of Land	Name of Land	Gazette Notice of Ownership	Share
Anibare	100	C.L.	Aribaeong	1/63	1/21
Anibare	121	C.L.	Anuquoge	34/61	1/42
Anibare	188	C.L.	Atoredeto	45/79	1/42
Anibare	217	P.L.	Atekapara	41/37	1/27
Anibare	324	C.L.	Ate	39/62	1/14
Baitsi	82	P.L.	Ugino	49/65	1/28
Ewa	7	C.L.	Arubo	49/65	1/28
Ewa	26	P.L.	Arida	22/66	1/28
Ewa	144	C.L.	Anuer	49/65	1/28
Ewa	153	C.L.	Mamweiya	43/66	1/28
Ewa	186	C.L.	Boroboron	51/71	1/28
Ewa	204	C.L.	Boroboron	11/75	1/7
Ijuw	7	P.L.	Ebara	1/73	1/28
Ijuw	31	C.L.	Ganakoro	39/62	1/7
Ijuw	34	C.L.	Ganakoro	49/65	1/28
Ijuw	35	C.L.	Eatdebruarik	49/65	1/28
Ijuw	53	C.L.	Ganakoro	49/65	1/28

G.N. No.130/1983

DETERMINATION OF BENEFICIARIES

2. The Nauru Lands Committee has determined that the beneficiaries of the estate of the late Eideberenimadang Obeta are:-

(a) in respect of the land shown in paragraph 1 above :

District	Portion No.	Name of Land	Beneficiaries	Share
Anibare	100	Aribaeong	Myra B. Obeta	1/168
			(Binea G.Dengabeiyal	1/168
			(Benina B.Obeta	1/168
		Bwano Obeta	(Madeline B. Obeta	1/168
		T/ee	(Robert B. Obeta	1/168
			(Thelmandy B.Obeta	1/168
			(Lyma B.Obeta	1/168
			(Bwano Obeta (LTO)	1/168
Anibare	121	Anuquoge	Myra B.Obeta	1/336

G.N. No.130/1983(Cont'd)

			Binea G.Dengabeiya	1/336
		Bwano Obeta	(Benina B.Obeta	1/336
		T/ee.	(Madeline B.Obeta	1/336
			(Robert B.Obeta	1/336
			(Thelmandy B.Obeta	1/336
			(Lyma B.Obeta	1/336
			Bwano Obeta (LTO)	1/336
Anibare	188	Atoredeto	Myra B.Obeta	1/336
			Binea G.Dengabeiya	1/336
		Bwano Obeta	(Benina B.Obeta	1/336
		T/ee.	(Madeline B.Obeta	1/336
			(Robert B.Obeta	1/336
			(Thelmandy B.Obeta	1/336
			(Lyma B.Obeta	1/336
			Bwano Obeta (LTO)	1/336
Anibare	217	Atekapara	Myra B.Obeta	1/216
			Binea G.Dengabeiya	1/216
		Bwano Obeta	(Benina B.Obeta	1/216
		T/ee.	(Madeline B.Obeta	1/216
			(Robert B.Obeta	1/216
			(Thelmandy B.Obeta	1/216
			(Lyma B.Obeta	1/216
			Bwano Obeta (LTO)	1/216
Anibare	324	Ate	Myra B.Obeta	1/112
			Binea G.Dengabeiya	1/112
		Bwano Obeta	(Benina B.Obeta	1/112
		T/ee.	(Madeline B.Obeta	1/112
			(Robert B.Obeta	1/112
			(Thelmandy B.Obeta	1/112
			(Lyma B.Obeta	1/112
			Bwano Obeta (LTO).	1/112
Baitsi	82	Ugino	Myra B.Obeta	1/224
			Binea G.Dengabeiya	1/224
		Bwano Obeta	(Benina B.Obeta	1/224
		T/ee.	(Madeline B.Obeta	1/224
			(Robert B.Obeta	1/224
			(Thelmandy B.Obeta	1/224
			(Lyma B.Obeta	1/224
			Bwano Obeta (LTO)	1/224
Ewa	7	Arubo	As for portion No.82 Baitsi	
Ewa	26	Arida	As for portion No.82 Baitsi	
Ewa	144	Anuer	As for portion No.82 Baitsi	
Ewa	153	Mamweiya	As for portion No.82 Baitsi	
Ewa	186	Boroboron	As for protion No. ⁸² Baitsi	
Ewa	204	Boroboron	Myra B.Obeta	1/56
			Binea G.Dengabeiya	1/56

G.N. No.130/1983 (Cont'd)

		Bwano Obeta T/ee.	(Madeline B.Obeta (Robert B.Obeta (Thelmandy B.Obeta (Benina B. Obeta (Lyma B.Obeta Bwano Obeta (LTO)	1/56 1/56 1/56 1/56 1/56 1/56
Ijuw	7	Ebara	As for portion No.82	Baitsi
Ijuw	31	Ganakoro Bwano Obeta T/ee.	Myra B.Obeta Binea G.Dengabeiya (Madeline B.Obeta (Robert B.Obeta (Thelmandy B.Obeta (Benina B.Obeta (Lyma B.Obeta Bwano Obeta (LTO)	1/56 1/56 1/56 1/56 1/56 1/56 1/56
Ijuw	34	Ganakoro	As for portion No.82	Baitsi
Ijuw	35	Eatdabuarik	As for portion No.82	Baitsi
Ijuw	53	Ganokoro	As for portion No.82	Baitsi

NOTE: Any person who is dissatisfied with the distribution of the above estate may appeal to the Supreme Court within 21 days of the publication of this Gazette.

J.A. Daguape
VICE CHAIRMAN

G.N. No.131/1983

LAND TRANSFER

It is notified for general information, that the following transfer of phosphate land has been approved by His Excellency the Acting President.

District	Port No.	Land Name	Original Owner	Share	Gazette	Proposed Owner	Share
Anibare	338	Idonga	Eamwemwe Bernicke	1/14	12/76	Louise B. Bernicke	1/14

J.A. Daguape
VICE CHAIRMAN.

DISTRICT OF YAREN

SCALE: 50'="

G.N.No. 132/83



CLASSIFICATION OF LAND

BY VIRTUE of the powers vested in me by SECTION 7 of the LANDS ACT 1976, I HEREBY classify the land shown hatched on the plan herein as NON-PHOSPHATE BEARING.

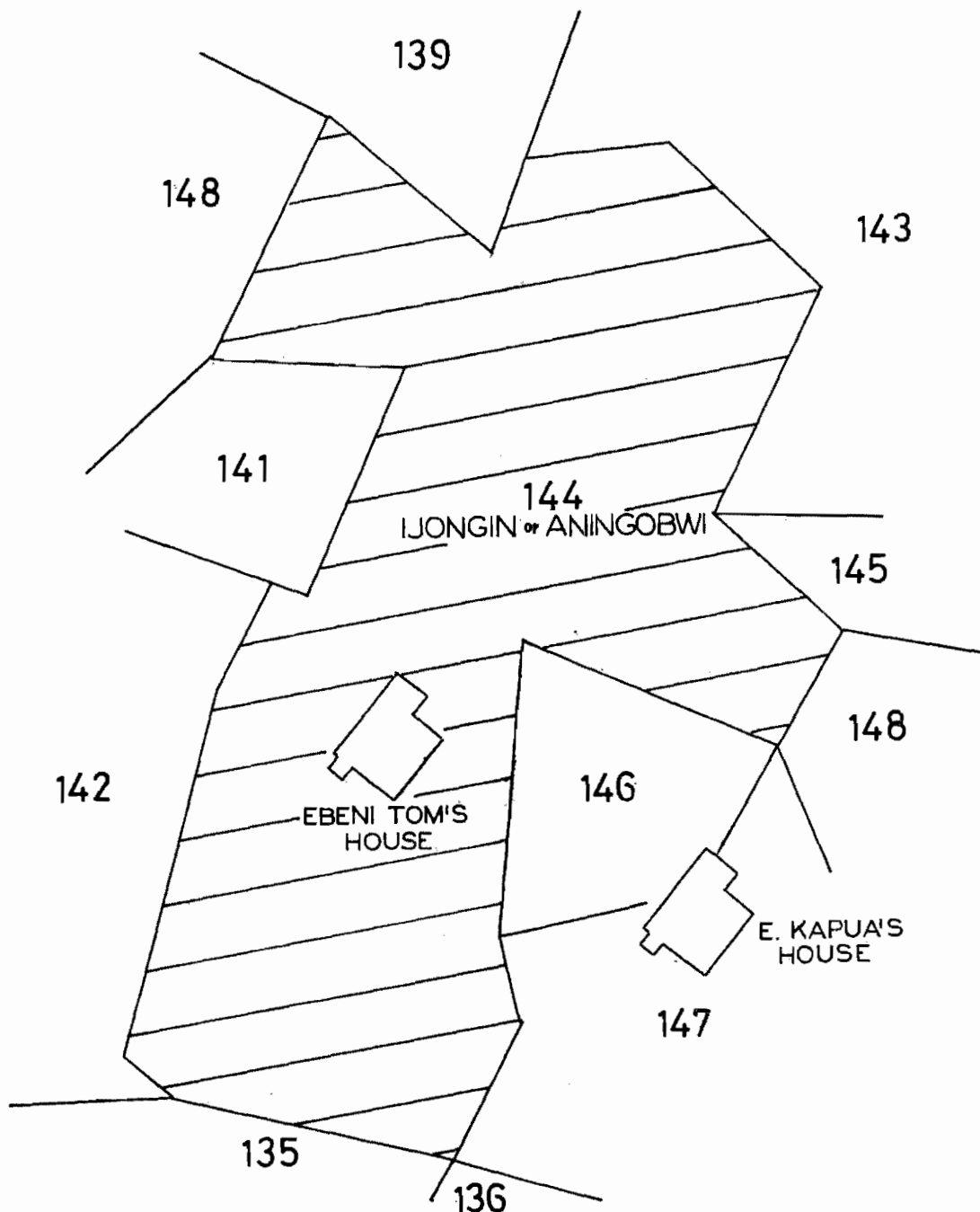

J. D. AUFUA
J. D. AUFUA
MINISTER
FOR ISLAND DEVELOPMENT & INDUSTRY.

DISTRICT OF YAREN
SCALE: 50' = 1"

G.N.No. 133/83

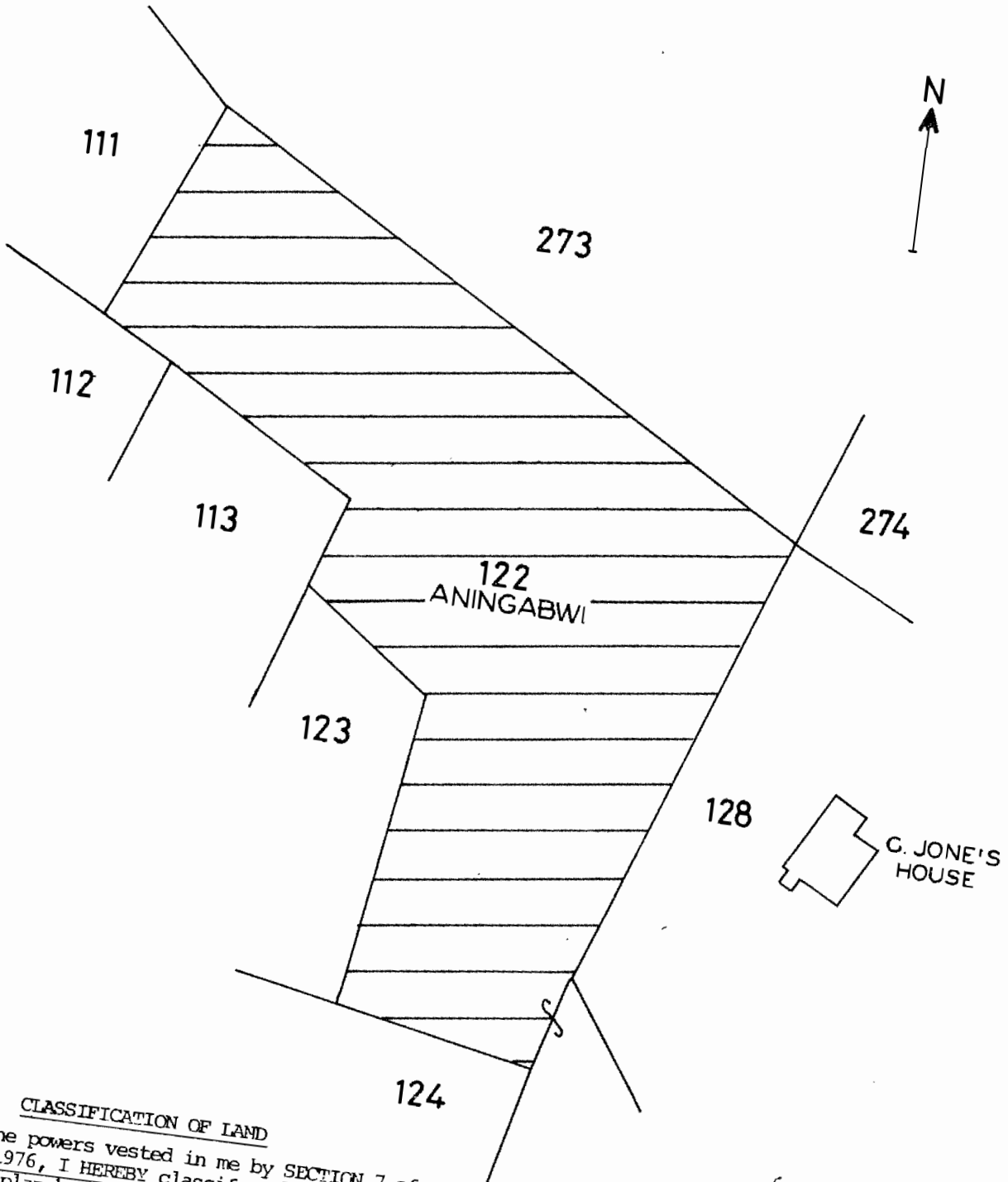

CLASSIFICATION OF LAND
IN VIRTUE of the powers vested in me by SECTION 7 of
LANDS ACT 1976, I HEREBY classify the land shown
on the plan herein as NON-PHOSPHATE BEARING.

J. D. Audoa
J. D. AUDOA
MINISTER
FOR ISLAND DEVELOPMENT & INDUSTRY

DISTRICT OF ANIBARE

SCALE: 50' = 1"



CLASSIFICATION OF LAND

BY VIRTUE of the powers vested in me by SECTION 7 of the LANDS ACT 1976, I HEREBY classify the land shown hatched on the plan herein as NON-AGRICULTURE RESERVE.

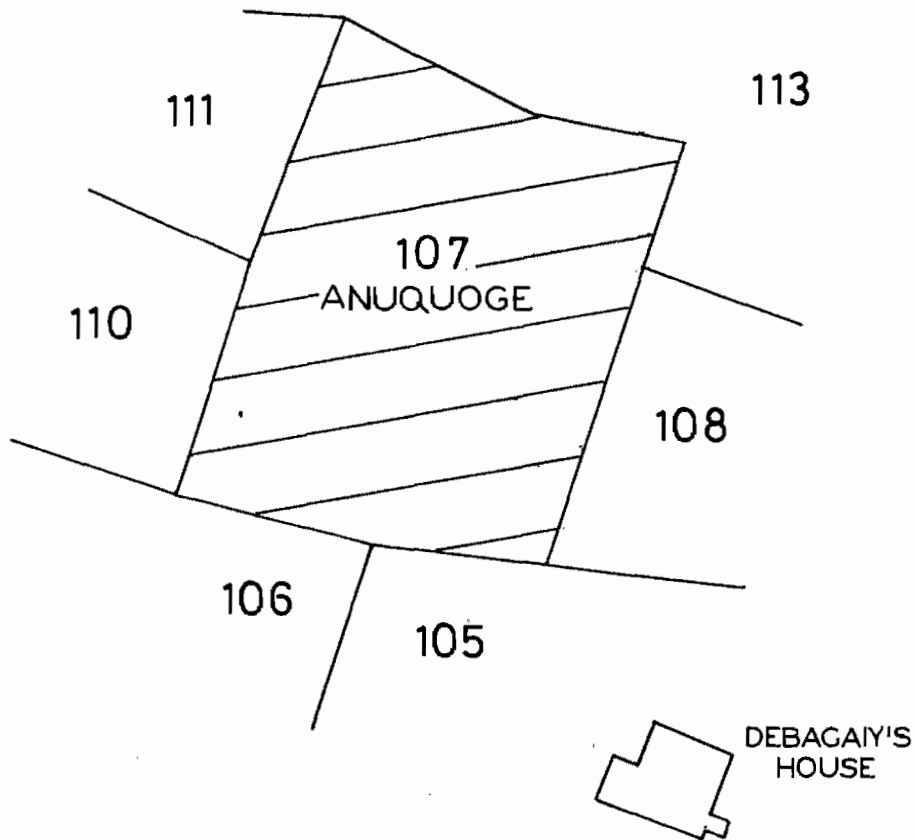

[Signature]
J. D. AUTON
ADMINISTRATOR

FOR ISLAND DEVELOPMENT & INDUSTRY.