



REPUBLIC OF NAURU

Government Gazette

Published by Authority

No. 14

5th March, 1980

Nauru.

G.N.No. 72/1980

PUBLIC SERVICE ACT 1961-1979

SECTION 22

NOTIFICATION OF PROMOTION

The provisional promotion of the following officer with effect from 1 February 1980 is advised :

DEPARTMENT OF TELECOMMUNICATIONS

<u>NAME</u>	<u>PROMOTED FROM</u>	<u>PROMOTED TO</u>
David J. SANSON	Crossbar Technician T8 \$8232 - 8556	Crossbar Engineer/Tech. T9 \$8820 - 9240

Any officer of the Public Service may appeal against the above promotion as provided under Section 25 of the Public Service Act. Appeals should be based on one or other of the grounds set out in Section 25 (2) and should be lodged in writing stating the grounds of appeal, with the Public Service Commissioner within seven days after the date of this Gazette.

Dated this 27th day of February, 1980

G.S. MATAIKA
CHIEF SECRETARY.

G.N. No. 73/1980

CORRIGENDUM

FILLING OF VACANCIES

In Gazette Notice No. 47/1980 of 6 February 1980 an incorrect salary scale for the position of Laboratory Technologist was advertised. The correct salary is -

No. 14

5th March, 1980

Nauru.

G. N. No. 73/1980 (Cont'd)

Laboratory Technologist T6-T8 \$5786 - 6842.

G.S. MATAIKA
CHIEF SECRETARY

G. N. No. 74/1980

PUBLIC SERVICE ACT 1961-1975VACANCIES : SECTION 20

Applications are invited from Nauruans, both inside and outside the Public Service, for appointment, promotion or transfer to the following position -

Department of Island Development & Industry

(Directorate of Telecommunications)

Position : Crossbar Technician's Assistant

Salary: T1/T4 \$4130 - \$5462

Duties : The successful applicant will assist the Telephone Technician in installation and maintenance work on the island telephone network.

Qualifications: Applicants should have some knowledge of telephone installation, cable splicing and must possess a current driver's licence to cover trucks up to 3.5 tons capacity. It is preferable that applicants have some experience of light earth moving equipment operation.

Applications should be lodged in writing stating name, age, education, qualifications and experience with the Chief Secretary (C/- S. A. O.) before 4.30 p.m. on Friday, 14 March, 1980.

G. S. MATAIKA
PUBLIC SERVICE COMMISSIONER.

G.N. No. 75/1980

Determination of the Beneficiaries of the Estate of the late Capelle Susannah of Ewa District.

E S T A T E

1. The Nauru Lands Committee has ascertained that the late C. Susannah had been determined by the decisions of the Nauru Lands Committee (or its predecessor the Lands Committee) to be the owner of the following land :

District	Portion No	Type of Land	Name of Land	Gazette Notice of Ownership	Share
DENIG	209	CL.	ATUMURUMUR	39/52	1/28

G.N. No. 75/1980

DETERMINATION OF BENEFICIARIES

2. The Nauru Lands Committee has determined that the beneficiaries of the estate of the late Susannah. C. are:-

(a) in respect of the land shown in paragraph 1 above:

DISTRICT	PORTION NO.	NAME OF LAND	BENEFICIARIES	SHARE
DENIG	209	ATUMURUMUR	Selina E. Bill Beyura A. Capelle Maureen Craven Heather Gadoangin Sophia Oppenheimer	1/224 1/224 1/244 1/244 1/244

No. 14

5th March, 1980

Nauru.

G.N. No. 75/1980 (Cont'd)

Halsey Capelle 1/224
Richard Capelle (LTO) 1/224

James H. (Luane Harris 1/1344
(Nahesson Harris 1/1344
(Jesse Harris 1/1344
(Anna Harris 1/1344
(Dania Harris 1/1344
(James Harris (LTO) 1/1344

NOTE:

The Nauru Lands Committee's decision as to the beneficiaries of the estate of the late Susannah C. was published in Gazette No. 34/77.

Any person who is dissatisfied with the distribution of the above estate may appeal to the Supreme Court within 21 days of the publication of this Gazette.

Dated this 21st day of February, 1980.

J.A. DAGUAPE
VICE CHAIRMAN

G.N. No. 76/1980

Determination of the Beneficiaries of the Estate of the late Dowouw Eidebauw of Buada District.

E S T A T E

1. The Nauru Lands Committee has ascertained that the late D. Eidebauw had been determined by the decisions of the Nauru Lands Committee (or its predecessor the Lands Committee) to be the owner of the following land :

District	Portion No.	Type of Land	Name of Land	Gazette Notice of Ownership	Share
Denig	153	CL.	ATUMURUMUR	38/52	1/7
Denig	209	CL.	ATUMURUMUR	38/52	1/7

G. N. No. 76/1980

DETERMINATION OF BENEFICIARIES

2. The Nauru Lands Committee has determined that the beneficiaries of the estate of the late Eidebauw D. are:-

(a) in respect of the land shown in paragraph 1 above:

G.N. No. 76/1980 (Cont'd)

DISTRICT	PORTION NO.	NAME OF LAND	BENEFICIARIES	SHARE
DENIG	153	ATUMURUMUR	Mary N. Peo Lynors Abemama Douwouw (LTO)	1/28 1/28 1/14
DENIG	209	ARUMURUMUR	-do-	-do-

NOTE:

The Nauru Lands Committee's decision as to the beneficiaries of the estate of Eidebauw D. was published in Gazette No 21/76 and 34/77.

Any person who is dissatisfied with the distribution of the above estate may appeal to the Supreme Court within 21 days of the publication of this Gazette.

Dated this 21st day of February, 1980.

J.A. DAGUAPE
VICE CHAIRMAN

G.N. No. 77 /1980

Determination of the Beneficiaries of the Estate of the late Dowaiti Mwareow of Nibok District.

E S T A T E

1. The Nauru Lands Committee has ascertained that the late D. Mwareow had been determined by the decisions of the Nauru Lands Committee (or its predecessor the Lands Committee) to be the owned of the following land :

District	Portion No.	Type of Land	Name of Land	Gazette Notice of Ownership	Share
DENIG	153	CL.	ATUMURUMUR	38/52	1/7
DENIG	209	CL.	ATUMURUMUR	38/52	1/7

G.N. No. 77/1980

DETERMINATION OF BENEFICIARIES

2. The Nauru Lands Committee has determined that the beneficiaries of the estate of the late Mwareow D. are:-

(a) in respect of the land shown in paragraph 1 above:-

No.14

5th March, 1980

Nauru.

G.N. No. 77/1980 (Cont'd)

DISTRICT	PORTION NO.	NAME OF LAND	BENEFICIARIES	SHARE
DENIG	153	ATUMURUMUR	Dennet D. Mwareow Ruth E. Mwareow Boborak Mwareow Salma E. Mwareow Rebecca Mwareow Serra Mwareow Bodererok Mwareow Magdalena T. Mwareow	1/56 1/56 1/56 1/56 1/56 1/56 1/56 1/56
-do-	209	-do-	-do-	-do-

NOTE:

The Nauru Lands Committee's decision as to the beneficiaries of the estate of Mwareow D. was published in Gazette No. 34/77.

Any person who is dissatisfied with the distribution of the above estate may appeal to the Supreme Court within 21 days of the publication of this Gazette.

Dated this 21st day of February, 1980.

J. A. DAGUAPE
VICE CHAIRMAN

G.N. No. 78/1980

Determination of the Beneficiaries of the Estate of the late Dowaiti Samson of Uaboe District.

E S T A T E

1. The Nauru Lands Committee has ascertained that the late D. Samson had been determined by the decisions of the Nauru Lands Committee (or its predecessor the Lands Committee) to be the owned of the following land :

District	Portion No	Type of Land	Name of Land	Gazette Notice of Ownership	Share
DENIG	153	CL.	ATUMURUMUR	38/52	1/7
DENIG	209	CL.	ATUMURUMUR	39/52	1/7

G.N. No. 78/1980

DETERMINATION OF BENEFICIARIES

2. The Nauru Lands Committee has determined that the beneficiaries of the estate of the late Samson D. are :-

(a) in respect of the land shown in paragrapj 1 above :-

No. 14

5th March, 1980

Nauru.

G.N. No. 78/1980 (Cont'd)

DISTRICT	PORTION NO.	NAME OF LAND	BENEFICIARIES	SHARE
DENIG	153	ATUMURUMUR	May M. Deireragea Alma Tero Delano A. Samson Enfanta D. Edoar Lo-Ruahma Samson	1/49 1/49 1/49 1/49 1/49
		LO-RUAHMA S. May M.D. T/ee	T/ee(Gerry Denloe Samson (Dennis D. Samson	1/49 1/49
-do-	209	-do-	-do-	-do-

NOTE:

The Nauru Lands Committee's decision as to the beneficiaries of the estate of Samson D. was published in Gazette No. 17/74.

Any person who is dissatisfied with the distribution of the above estate may appeal to the Supreme Court within 21 days of the publication of this Gazette.

Dated this 21st day of February, 1980.

J.A. DAGUAPE
VICE CHAIRMAN

G.N. No. 79/1980

Determination of the Beneficiaries of the Estate of the late Samson Pauline of Uaboe District.

E S T A T E

1. The Nauru Lands Committee has ascertained that the late S. Pauline had been determined by the decisions of the Nauru Lands Committee (or its predecessor the Lands Committee) to be the owner of the following land :

District	Portion No.	Type of Land	Name of Land	Gazette Notice of Ownership	Share
ANIBARE	201	PL.	BOGETSIW	35/74	1/36

G.N. No. 79/1980

DETERMINATION OF BENEFICIARIES

2. The Nauru Lands Committee has determined that the beneficiaries of the estate of the late Pauline S. are:-

(a) in respect of the land shown in paragraph 1 above

No. 14

5th March, 1980

Nauru.

G.N. No. 79/1980(Cont'd)

DISTRICT	PORTION NO.	NAME OF LAND	BENEFICIARIES	SHARE
Anibare	201	BOGETSIW	Gerry Kenloe Samson (Lo-Ruahma S. T/ee)	1/36

NOTE:

The Nauru Lands Committee's decision as to the beneficiaries of the estate of Pauline S. was published in Gazette No. 51/76.

Any person who is dissatisfied with the distribution of the above estate may appeal to the Supreme Court within 21 days of the publication of this Gazette.

Dated this 21st day of February, 1980.

J. A. DAGUAPE
VICE CHAIRMAN

G.N. No. 80/1980

Determination of the Beneficiaries of the Estate of the late Samson Raboia of Uaboe District.

E S T A T E

1. The Nauru Lands Committee has ascertained that the late S. Raboia had been determined by the decisions of the Nauru Lands Committee (or its predecessor the Lands Committee) to be the owned of the following land :

District	Portion No.	Type of Land	Name of Land	Gazette Notice of Ownership	Share
Anibare	201	PL.	BOGETSIW	35/74	1/36

G.N. No. 80/1980

DETERMINATION OF BENEFICIARIES

2. The Nauru Lands Committee has determined that the beneficiaries of the estate of the late Raboia S. are:-

(a) in respect of the land shown in paragraph 1 above :

G.N. No. 80/1980 (Cont'd)

DISTRICT	PORTION NO.	NAME OF LAND	BENEFICIARIES	SHARE
ANIBARE	201	BOGETSIW	May M. Deireragea	1/252
			Alma Tero	1/252
			Delano A. Samson	1/252
			Enfanta D. Edoar	1/252
			Lo- Ruahma Samson	1/252
			May D. T/ee (Dennis D. Samson)	1/252
		Lo-Ruahma T/ee (Gerry K. Samson)	1/252	

NOTE:

The Nauru Lands Committee's decision as to the beneficiaries of the estate of Raboia S. was published in Gazette No. 35/76.

Any person who is dissatisfied with the distribution of the above estate may appeal to the Supreme Court within 21 days of the publication of this Gazette.

Dated this 21st day of February, 1980.

J. A. DAGUAPE
VICE CHAIRMAN

G.N. No. 81/1980

Determination of the Beneficiaries of the Estate of the late Boiya Drake of Yaren District.

E S T A T E

1. The Nauru Lands Committee has ascertained that the late Drake B. had been determined by the decisions of the Nauru Lands Committee (or predecessor the Lands Committee) to be the owned of the following land :

District	Portion No.	Type of Land	Name of Land	Gazette Notice of Ownership	Share
DENIG	209	CL.	ATUMURUMUR	18/69	1/168

G.N.No. 81/1980

DETERMINATION OF BENEFICIARIES

2. The Nauru Lands Committee has determined that the beneficiaries of the estate of the late Drake B. are:-

(a) in respect of the land shown in Paragraph 1 above :

No. 14

5th March, 1980

Nauru.

G.N.No. 81/1980 (Cont'd)

District	Portion No.	Name of Land	Beneficiaries	Share
DENIG	209	ATUMURUMUR	Lavinia Deirame Eibiaun M. Solomon	1/336 1/336

NOTE:

The Nauru Lands Committee's decision as to the beneficiaries of the estate of Drake B. was published in Gazette No. 36/77.

Any person who is dissatisfied with the distribution of the above estate may appeal to the Supreme Court within 21 days of the publication of this Gazette.

Dated this 26th day of February, 1980.

J. A. DAGUAPE
VICE CHAIRMAN

G.N. No. 82/1980

Determination of the Beneficiaries of the Estate of the late Tangirau Janet of Nibok District.

E S T A T E

1. The Nauru Lands Committee has ascertained that the late Janet T. had been determined by the decisions of the Nauru Lands Committee (or its predecessor the Lands Committee) to be the following land :

District	Portion No.	Type of Land	Name of Land	Gazette Notice of Ownership	Share
DENIG	209	CL.	ATUMURUMUR	44/69	1/140

G.N.No 82/1980

DETERMINATION OF BENEFICIARIES

2. The Nauru Lands Committee has determined that the beneficiaries of the estate of the late Janet T. are:-

(a) in respect of the land shown in Paragraph 1 above :-

District	Portion No.	Name of Land	Beneficiaries	Share
DENIG	209	ATUMURUMUR	(Syvilla C. Tangiro (Ivan N. T. (Cynthia J. T. (Brigida T. (Jane F. T.	1/700 1/700 1/700 1/700 1/700

No. 14

5th March, 1980.

Nauru.

G.N. No. 82/1980 (Cont'd)

NOTE:

The Nauru Lands Committee's decision as to the beneficiaries of the estate of Janet T. was published in Gazette No. 58/79.

Any person who is dissatisfied with the distribution of the above estate may appeal to the Supreme Court within 21 days of the publication of this Gazette.

Dated this 26th day of February, 1980

J. A. DAGUAPE
VICE CHAIRMAN

G.N. No. 83/1980

Determination of the Beneficiaries of the Estate of the late Aeonamwa Eigageiwa of Uaboe District.

E S T A T E

1. The Nauru Lands Committee has ascertained that the late Eigageiwa A. had been determined by the decisions of the Nauru Lands Committee (or its predecessor the Lands Committee) to be the owned of the following land :

District	Portion No.	Type of Land	Name of Land	Gazette Notice of Ownership	Share
DENIG	209	CL.	ATUMURUMUR	10/74	1/63 (LTO)

G.N. No. 83/1980

DETERMINATION OF BENEFICIARIES

2. The Nauru Lands Committee has determined that the beneficiaries of the estate of the late Eigageiwa A. are:-

(a) in respect of the land shown in paragraph 1 above :

DISTRICT	PORTION NO.	NAME OF LAND	BENEFICIARIES	SHARE
DENIG	209	ATUMURUMUR	Mary, Kunkura Kun Joakim Edgar J. Eugene A. J. Obeira J. Agnes Randerok Garret Herman (Est. of	1/126 1/756 1/756 1/756 1/756 1/756 1/756

G.N. No.83/1980 (Cont'd)

NOTE:

The Nauru Lands Committee's decision as to the beneficiaries of the estate of Eigageiwa A. was published in Gazette N. 51/74.

Any person who is dissatisfied with the distribution of the above estate may appeal to the Supreme Court within 21 days of the publication of this Gazette.

Dated this 26th day of February, 1980.

J. A. DAGUAPE
VICE CHAIRMAN

G.N. No. 84/1980

Determination of the Beneficiaries of the Estate of the late Ismael Aoenamwa of Uaboe District.

E S T A T E

1. The Nauru Lands Committee has ascertained that the late Aoenamwa I. had been determined by the decisions of the Nauru Lands Committee (or its predecessor the Lands Committee) to be the owned of the following land :

District	Portion No.	Type of Land	Name of Land	Gazette Notice of Ownership	Share
DENIG	153	CL.	ATURUMURUMUR	38/52	1/21

G.N No. 84/1980

DETERMINATION OF BENEIFCIARIES

2. The Nauru Lands Committee has determined that the beneficiaries of the estate of the late Aeonamwa I. are :-

(a) in respect of the land shown in paragraph 1 above:

DISTRICT	PORTION NO.	NAME OF LAND	BENEFICIARIES	SHARE
DENIG	153	ATUMURUMUR	Mary Kunkura Kun Joakim Edgar J. Eugene A. J. Obeira J. Agnes Randerok Garret Herman (Est. of)	1/42 1/252 1/252 1/252 1/252 1/252 1/252

G.N. No.84/1980 (Cont'd)

NOTE:

The Nauru Lands Committee's decision as to the beneficiaries of the estate of Aeonamwa was published in Gazette No. 15/74.

Any person who is dissatisfied with the distribution of the above estate may appeal to the Supreme Court within 21 days of the publication of this Gazette,

Dated this 26th day of February, 1980.

J. A. DAGUAPE
VICE CHAIRMAN

CLASSIFICATION OF LAND

BY VIRTUE of the powers vested in me by SECTION 7 of the LANDS ACT 1976, I HEREBY classify the land shown hatched on the plan hereunder as NON-PHOSPHATE BEARING.

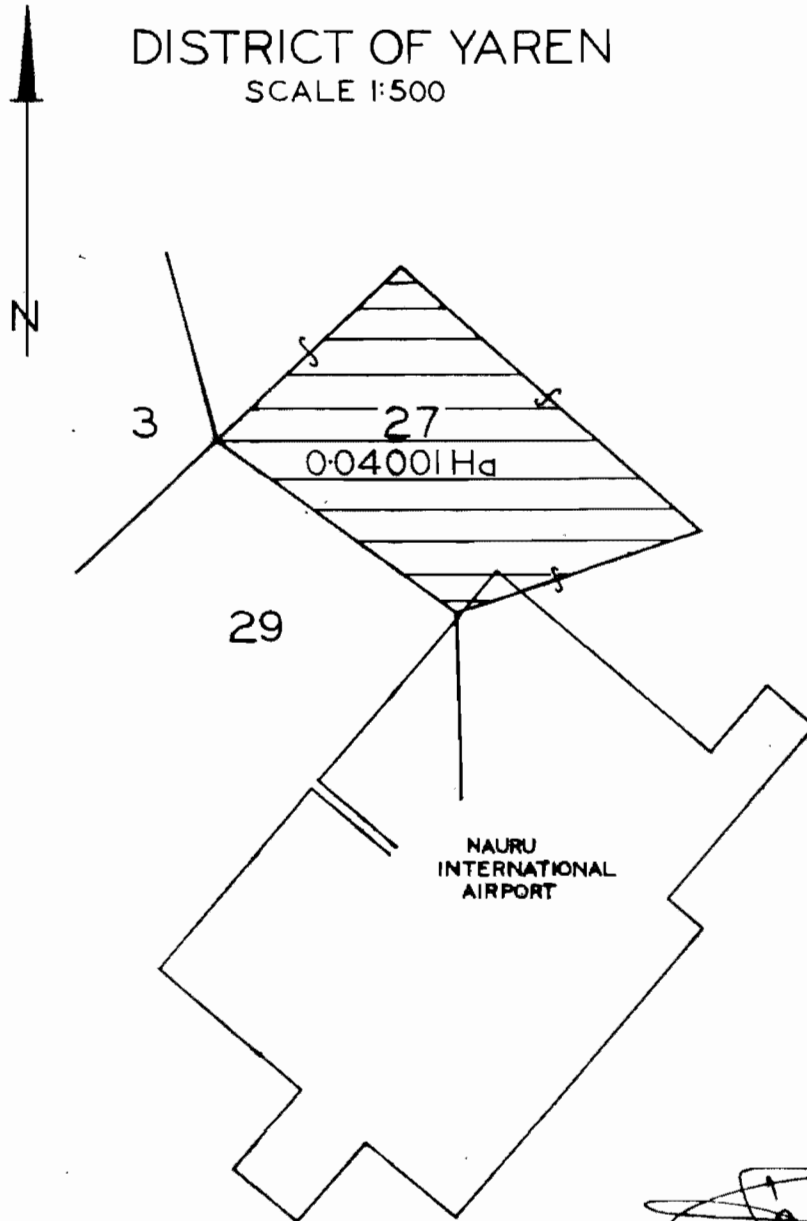

K. ARORA
ACTING MINISTER

FOR ISLAND DEVELOPMENT AND INDUSTRY